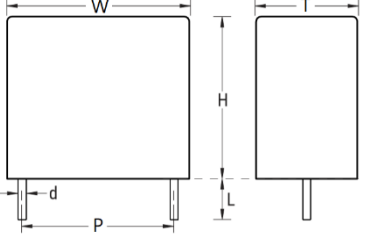
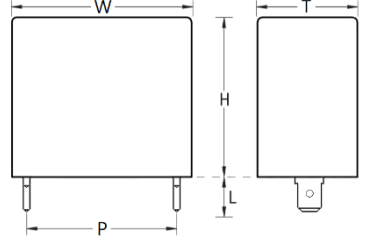
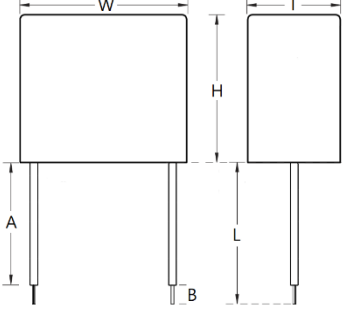

AC Film Capacitor Incl. Motor run, Class S3

■ 電容器圖紙和端子樣式 Capacitor Drawings and Terminal Styles

鍍錫引線 Tinned Lead Wires	扁平快速連接 Flat quick connectors	絕緣軟電線 Insulated Flexible wires
		

■ 典型應用

廣泛應用於 50Hz/60Hz 頻率功率下的交流單相電機的啟動和運行，要求電機運行 S3 安全分類。

■ 特徵

金屬化聚丙烯薄膜徑向鍍錫引線或電纜線，電容器封裝在自熄耐溶劑塑料殼中，採用符合 UL 94 V-0 要求的熱固性樹脂材料。

■ Typical Applications

Widely applied to starting and running of AC Single-phase motors at 50Hz/60Hz frequency power

■ Features

Metallized polypropylene film with radial leads of tinned wire or cable. The capacitor is encapsulated in a self-Extinguishing solvent resistant plastic case with thermosetting resin material meeting UL 94 V-0 requirements.

■ 規格 Specifications

參考標準 Reference Standard	GB/T 3667.1 (IEC 60252-1)			
容量範圍 Capacitance Range	CQC	VDE	UL	
	0.50 $\mu$ F ~15 $\mu$ F	0.50 $\mu$ F ~15 $\mu$ F	0.50 $\mu$ F ~50 $\mu$ F	
容量誤差 Capacitance Tolerance	$\pm 5\%$ (J)			
額定交流電壓 Rated AC Voltage - 50/60 Hz ( $U_N$ )	250Vac	300Vac	350Vac	400Vac 450Vac
工作溫度範圍 Operating Temperature Range	-40°C~85°C			
安全防護等級 Class of Safety Protection	S3			
運行等級-預期壽命 Operating Class-Life Expectancy	Class C 3000 hours			
耐電壓 Voltage Proof	引線間 Between Terminals	2 x $U_N$ for 2 seconds		
	引線與外殼間 Between Terminal and Case	2,000 Vac, 2 seconds		
最大允許電壓 Maximum Permissible Voltage	1.10 x rated voltage			
最大允許電流 Maximum Permissible Current	1.30 x rated current			
損耗因素 Dissipation Factor	$\leq 20 \times 10^{-4}$ at 20°C, 100kHz			
絕緣電阻 Insulation Resistance	$IR \times C_N \geq 3000$ s (100Vdc, 60sec / 20°C)			

AC Film Capacitor Incl. Motor run, Class S3

■ 產品代碼構成 Product code system

鍍錫引線和扁平快速連接 For Tinned Lead Wires and Flat quick-connectors

SMS3	H	105	J	TB39	F	T	32	15
型號 Type	內部使用 Internal Use	容值 Capacitance	公差 Tolerance	外殼代碼 Case Code	額定電壓 Rated Voltage	端子樣式 Terminal Style	引線間距 Lead Pitch	引線長度 Lead Length
SMS3= AC Film Capacitor Incl. Motor Run Class- S3	--	105 =1000nF =1.0μF	J=±5%	TB40= 48*37*26 More...	A=200Vac B=250Vac C=300Vac D=350Vac E=400Vac F=450Vac	Shown as Table I (表一)	28=27.5mm 32=31.5mm 38=37.5mm 43=42.5mm 53=52.5mm	04=3.5mm 15=15mm 23=23mm DP= Flat quick- connectors

絕緣軟電線 For Insulated Flexible wires

SMS3	H	105	J	TB39	F	20	080
型號 Type	內部使用 Internal Use	容值 Capacitance	公差 Tolerance	外殼代碼 Case Code	額定電壓 Rated Voltage	電線代碼 Cable Code	電線長度 Cable Length
SMS3= AC Film Capacitor Incl. Motor Run Class- S3	--	105 =1000nF =1.0μF	J=±5%	TB39= 38*26*16 More...	A=200Vac B=250Vac C=300Vac D=350Vac E=400Vac F=450Vac	18=1015 AWG 18 20=1015 AWG 20 22=1015 AWG 22	060=60mm 080=80mm 100=100mm 120=120mm 150=150mm

(表一) Table I

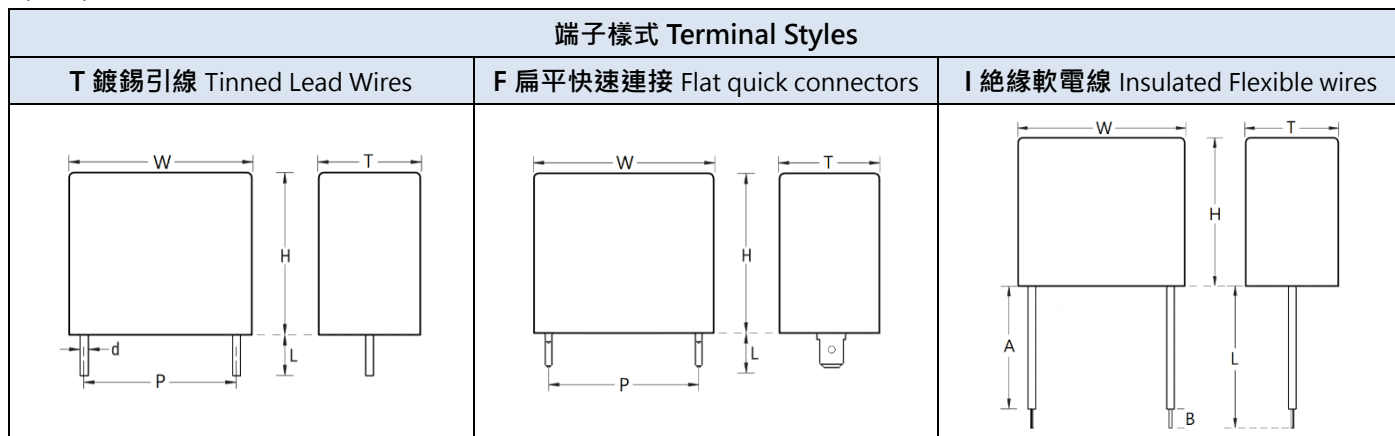

AC Film Capacitor Incl. Motor run, Class S3

■ 檢驗要求 Inspection requirements

測試項目 Test item	性能要求 Performance requirements	試驗條件 Conditions of test
例行試驗 Routine test		
5.7 引出端間的電壓試驗 Voltage test between terminals	應不發生閃絡或永久性擊穿 No flashover of permanent breakdown shall occur	引線間 Between terminals 2 x U <sub>N</sub> for 2 seconds
5.8 引出端與外殼的電壓試驗 Voltage test between terminals and case		引線與外殼間 Between terminals and case 2,000 Vac, 2 seconds
5.6 外觀檢查 Visual examination	產品工藝、標志及表面處理應符合要求 The condition, workmanship, marking and finish shall be satisfactory	目視檢查 Visual examination
5.9 電容測量 Capacitance measurement	在規定公差內 Within the tolerance specified	100Hz, 1Vrms Max. at 20°C
5.5 損耗角正切測量 Tangent of loss angle	≤ 20 x 10 <sup>-4</sup> at 100Hz	1Vrms Max. at 20°C
絕緣電阻 Insulation resistance	IR x C <sub>N</sub> ≥ 3000 s	100Vdc, 60sec / 20°C
試驗項目 Test items	性能要求 Performance requirements	試驗條件 Conditions of test
型式試驗 Type Tests		
5.11 機械試驗 Mechanical tests 5.11.1 引出端子強度 Robustness of terminations	每項試驗結束後對電容器進行外觀檢查，應無明顯損傷 After each of these tests the capacitors shall be visually examined. There shall be no visible damage.	拉力 Tensile U <sub>a</sub> (Duration : 10s±1s)
		對所有類型的引出端子施加的負荷均應為 20 N Loads apply: 20 N for all types of terminations
		彎曲 Bending U <sub>b</sub> (4x90° , Duration : 2 times/bend)
5.11.2 錫焊 Soldering	任何單根引線的面積至少 95% 範圍內無缺陷 No defect within at least 95% of the area of any single lead	可焊性 Solderability of wire and tag terminations
		IEC 60082-2-20 試驗 Ta <sub>1</sub> 焊槽法 Solder bath 焊接溫度 Solder temperature: 235±3°C 焊接時間 Solder time: 2±0.2sec
		耐焊接熱 Resistance to soldering heat
5.11.3 振動 Vibration	無可見損壞 No visible damage 電容在規定公差 Within the tolerance specified Voltage test between terminals and case: No permanent breakdown or flashover	IEC 60082-2-20 試驗 Tb <sub>1</sub> 焊槽法 Solder bath 焊接溫度 Solder temperature: 260±3°C 焊接時間 Solder time: 5±0.5sec
		頻率範圍 Frequency range: 10~55Hz 振幅軸向 Course: X、Y、Z (axis) 持續時間 2h / axis ( 6h in total) 位移振幅 Displacement amplitude: ±0.75mm





AC Film Capacitor Incl. Motor run, Class S3

■ 檢驗要求 Inspection requirements

試驗項目 Test items	性能要求 Performance requirements	試驗條件 Conditions of test
型式試驗 Type Tests		
5.14 濕熱試驗 Damp-heat test	在濕熱周期後·應將電容器放置恢復不少於 2 小時 After the damp-heat period, the capacitors shall be stored for recovery for not less than 2 h 最終測量結果 Final measurements (1) $\Delta C/C \leq 0.5\%$ of the initial value	溫度 Temperature: $40^{\circ}\text{C} \pm 2^{\circ}\text{C}$ 濕度 Relative humidity: $93 \pm 3\%$ 持續時間 Duration: 21 days
5.7 引出端間的電壓試驗 Voltage test between terminals	應不發生閃絡或永久性擊穿 No flashover of permanent breakdown shall occur	引線間 Between terminals $2 \times U_N$ for 60 seconds
5.8 引出端與外殼的電壓試驗 Voltage test between terminals and case		引線與外盒間 Between terminals and case 2,000 Vac, 60 seconds
5.15 自愈性試驗 Self-healing test	最終測量結果 Final measurements (1) $\Delta C/C \leq 0.5\%$ of the initial value (2) $RC \geq 100 \text{ s}$	電壓 200V/min 上升至 $2U_N$ , 直到發生 5 次自愈性擊穿, 或直到電壓達到最高值 $3.5 U_N$ 為止 The voltage rises to $2U_N$ at 200V/min, until 5 times self-healing breakdowns occur, or until the voltage reaches a maximum of $3.5U_N$
5.13 耐久性試驗 Endurance test	在試驗期間·應不發生永久性擊穿·開路或閃絡 During the test, no permanent breakdown, Interruption or flashover shall occur. 最終測量結果 Final measurements (1) $\Delta C/C \leq 3\%$ of the initial value	施加電壓 Apply voltage: $U_N \times 1.35 \text{ VAC}$ , 50 Hz 溫度 Temperature: $+85^{\circ}\text{C}$ 持續時間 Duration: 1000 hours
5.17.2 灼熱絲試驗 Glow-wire test	電容器移開火焰後·持續燃燒時間不得超過 30 s After removing test flame from capacitor, must not continue to burn for more than 30 s 綑紙不得點燃 The tissue paper shall not ignite	灼熱絲尖端的溫度為 $750 \pm 10^{\circ}\text{C}$ 持續時間 Duration: $30 \pm 1 \text{ seconds}$ 不適用於具有絕緣線狀引出端子的電容器 not applicable to capacitors with lead terminations

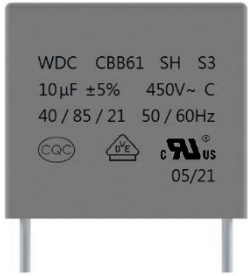
AC Film Capacitor Incl. Motor run, Class S3

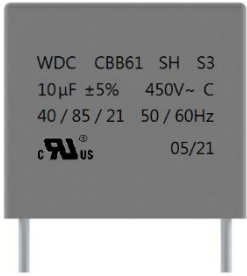
■ 標示 Marking (For Example)

$\geq 0.5\mu\text{F } C_N \leq 15\mu\text{F}$	$> 15\mu\text{F } C_N \leq 50\mu\text{F}$
 <p>WDC CBB61 SH S3 10µF ±5% 450V~ C 40 / 85 / 21 50 / 60Hz CQC   05/21</p>	 <p>WDC CBB61 SH S3 10µF ±5% 450V~ C 40 / 85 / 21 50 / 60Hz  05/21</p>
1. "WDC" is a trademark of WINDAY	2. Type of the Capacitors: CBB61
3. Self-Healing in nature such as SH	4. Class of Safety Protection: S3
5. Capacitance: 10µF	6. Capacitance Tolerance: ±5%
7. Rated Voltage: 450V~	8. Class of Operation: C
9. Climatic Category: 40/85/21	10. Working Frequency: 50/60Hz
11. Recognized Approval Mark	12. Date Code : 05/21, Month = 5, Year = 2021

■ CBB61-S3 型安全標準認證表 Approval sheets for safety standard of type CBB61-S3

認證標志 Approval marks	標準 Standards	證書號 Certificate	氣候類別 Climatic Category	容量範圍 Capacitance Range	額定電壓 Rated Voltage
	EN 60252-1:2011	40053555	40/85/21	0.50µF ~ 15µF	250Vac
	GB/T3667.1- 2016	CQC21002305222	40/85/21	0.50µF ~ 15µF	300Vac
	UL810 CSA.C22.2 No.190	E353342	Construction only	0.50µF ~ 50µF	350Vac
					400Vac
					450Vac

AC Film Capacitor Incl. Motor run, Class S3

■ 薄膜電容器焊接指南 Soldering Guidelines for Film Capacitors

聚丙烯膜電容器對熱特別敏感 (聚丙烯膜的熔點為 160°C ~ 170°C) , 波峰焊可能具有破壞性 , 尤其是對於小型聚丙烯膜電容器 (引線間距為 5 mm 至 15 mm) , 焊接過程中必須非常小心。

一般來說 , IEC 出版物 61760-1 第 2 版中的波峰焊接曲線可作為成功焊接的可靠指南。(請參見圖 1)

Polypropylene capacitors are especially sensitive to heat (the melting point of polypropylene is 160 – 170°C).

Wave soldering can be destructive, especially for mechanically small polypropylene capacitors (with lead spacing of 5 – 15 mm), and great care must be taken during soldering. In general, the wave soldering curve from IEC Publication 61760-1 Edition 2 serves as a solid guideline for successful soldering. See Figure 1.

通孔的薄膜電容器不建議採用回流焊。將電容器暴露在超過上述建議限值可能會導致電容器退化或永久性損壞。

Reflow soldering is not recommended for through-hole film capacitors. Exposing capacitors to a soldering profile in excess of the recommended limits may result in degradation or permanent damage to the capacitors.

請勿將聚丙烯膜電容器通過粘合劑固化爐來固化表面安裝部件的樹脂 , 須在表面安裝零件固化後插入通孔零件。

如果通孔部件必須通過粘合劑固化過程 , 請諮詢 WINDAY , 討論烘箱中的實際溫度分布。

建議最多進行兩次焊接循環。在第二次焊接循環之前 , 請留出時間使電容器表面溫度恢復到正常溫度。

Do not place the polypropylene capacitor through an adhesive curing oven to cure resin for surface mount components.

Insert through-hole parts after curing the surface mount parts. Contact WINDAY to discuss the actual temperature profile in the oven, if through-hole components must pass through the adhesive curing process.

A maximum two soldering cycles is recommended.

Allow time for the capacitor surface temperature to return to normal before the second soldering cycle.

■ 波峰焊建議 Wave Soldering Recommendations (Figure 1)

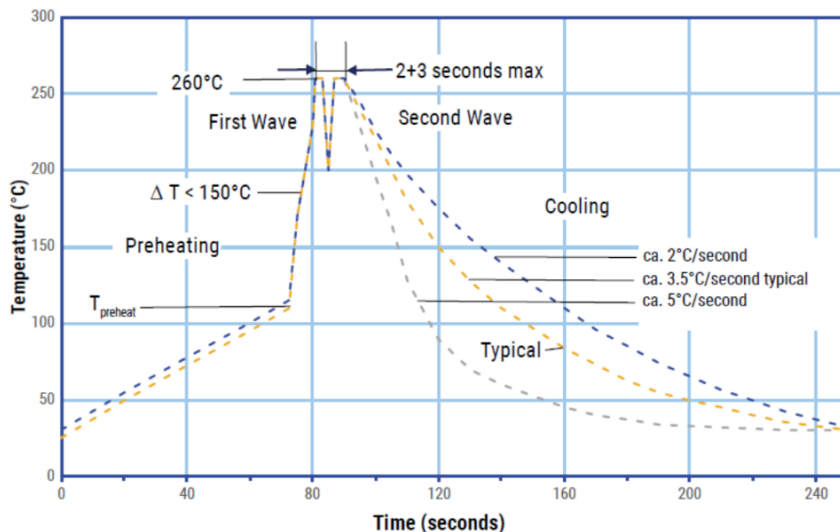

AC Film Capacitor Incl. Motor run, Class S3

■ 波峰焊建議 Wave Soldering Recommendations (Continue)

1. 該表顯示了焊接過程的最高設置溫度 The tables indicates the maximum set-up temperature of the soldering process

介電薄膜材料 Dielectric Film Material	最高預熱溫度 Max. Preheat Temperature		最高峰值焊接溫度 Max. Peak Soldering Temperature	
	Pitch ≤ 15 mm	Pitch > 15 mm	Pitch ≤ 15 mm	Pitch > 15 mm
聚乙酯膜 Polyester	130°C	130°C	270°C	270°C
聚丙烯膜 Polypropylene	110°C	130°C	260°C	270°C

2. 電容器內部測得的最高溫度 The maximum temperature measured inside the capacitor

介電薄膜材料 Dielectric Film Material	元件內部測得的最高溫度 Maximum Temperature Measured Inside the Element
聚乙酯膜 Polyester	160°C
聚丙烯膜 Polypropylene	110°C

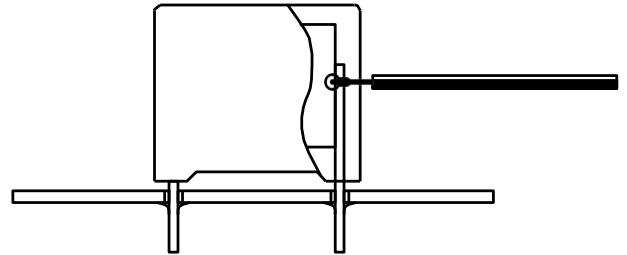

設置溫度，使元件內的最高溫度低於極限：

Set the temperature so that inside the element the maximum temperature is below the limit.

■ 儲存條件和期限 Storage conditions and duration

包裝好的電容器應存放在清潔、通風、乾燥的庫房內，不靠近熱源，不受陽光直射，嚴禁與化學試劑、酸和有害氣體一起儲存。T<sub>stg</sub> = +5°C 至 +35°C，最大相對濕度為 75%，無冷凝，儲存一年。

Packaged capacitors should be kept in clean, ventilated, dry coffers, not near the heat source, not subject to direct sunlight, is strictly prohibited and chemical reagents, acid and harmful gas storage together.

T<sub>stg</sub> = +5°C to +35°C with relative humidity of maximum 75% without condensation, storage for one year.